

Operation Instruction of SJT-YY Elevator Automatic Rescue Device

Shenyang Bluelight Mechatronics Co., Ltd.

January, 2008

Content

Warning.....	1
1. Introduction.....	2
2. Application scope.....	2
3. Specifications.....	2
4. Principles and functions.....	3
5. Installation and adjustment.....	3
6. Troubleshooting and Countermeasures.....	7
7. Major technical parameters.....	7
8. Maintenance and service.....	8

Warning

When the ARD is used in combination with YASKAWA 676GL5-JJ or YASKAWA Varispeed-L7B transducer, turn off the power to ensure safe operation conditions, disconnect PO with B1 and NO of transducer with - , remove the connecting wires between controlling cabinet PO and B1, and between NO and - , and then connect PO and NO into the ARD.

1. Introduction

SJT-YY Elevator Automatic Rescue Device is applied to emergency running when the electric grid is in an abnormal state. When elevator stops between floors due to power failure, the ARD can supply power to allow the elevator to slowly land on the nearest floor and enable the door of the elevator to be opened automatically with the battery provided in the ARD, so as to let the passengers out safely.

Through the coordination of the internal control circuit with transducer and microcomputer board, the ARD achieves automatic leveling function of elevators during power failure. Compared with similar traditional products, the ARD has the advantages of maximum utilization of the original resources of the control system, low price, high reliability and controlling flexibility.

2. Application scope

The ARD can be applied to the variable voltage & variable frequency elevator (VVVF elevator) driven by gearless permanent magnet synchronous motor or asynchronous motor.

3. Specifications

The specifications of the ARD are as followed:

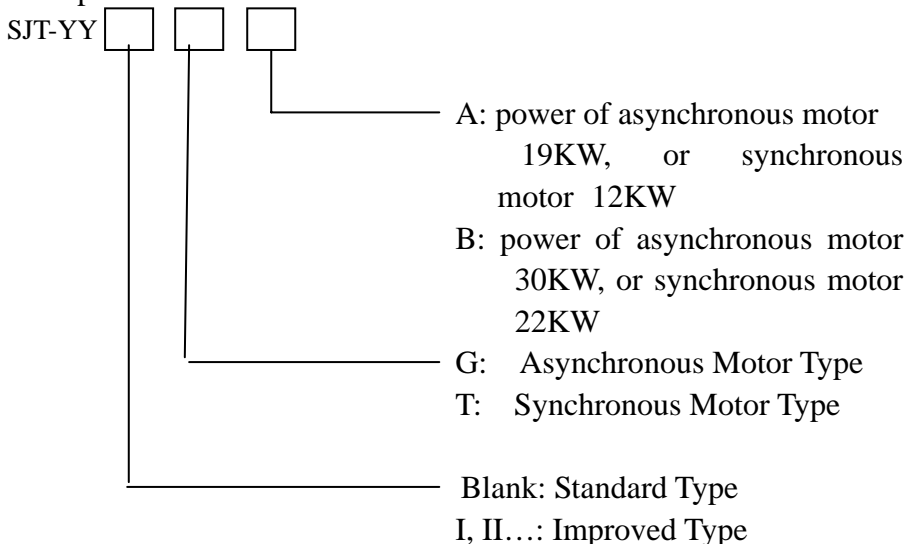

4. Principles and functions

During operation, the ARD supplies power and controlling signals to the transducer and the microcomputer board via the internal controlling circuit. The internal control unit, transducer and microcomputer board coordinate the elevator to move slowly and level onto the nearest floor and open the door. The detailed functions are as follows:

1. The ARD and the control system are electric interlocked reliably. When power is restored, the elevator runs normally.
2. The ARD runs only when all the following conditions are met:
 - ① Power supply is failed for elevator.
 - ② Elevator is not in the maintenance state.
 - ③ Elevator is not in the door zone.
 - ④ The signals of elevator safety circuit and door interlock circuit are normal.
3. If only one of the above conditions is not met while all the other conditions are met, the door of the elevator can be opened automatically by the ARD.
4. If the elevator is equipped with a load weighing device, in emergency the elevator runs in the direction which is determined by the loading condition.
5. The leveling is accurate, and the accuracy is up to $\pm 15\text{mm}$.
6. The ARD offers a maximum running time protection function (usually for 2 min).
7. The ARD offers an automatic constant voltage and constant current charging function.

5. Installation and adjustment

For the wiring diagram of the ARD and the SJT-WVF5 elevator control system manufactured by our company, see the attached diagram. For the wiring diagram of the ARD and the elevator control system manufactured by other company, refer to the above diagram, or designate our company to design the wiring.

1. The functions of the terminals in the ARD are defined as follows:

Operation Instruction of SJT-YY Elevator Automatic Rescue Device

Code	Description	Location	Instructions
PS1 PS2	Input power	CN1-1 CN1-12	PS1 and PS2 are input powers of the ARD, must be from one phase and neutral wire of the main power supply. AC220V±15% (50HZ±10%) is the power supply for the ARD and used to determine whether the electric grid is normal. Wires of 2mm ² are recommended.
Y5	Output signal for power failure	CN1-6	To separate the grounding terminal of braking voltage DC192V supplied by battery from the grounding terminal of the braking circuit (<u>only for synchronous system</u>).
BS+ BS-	Output power	TB1-1 TB1-2	BS+ and BS- are the output power, DC192V, to supply power for transducer. Wires of 4mm ² are recommended.
BK+ BK-	Output power (only for synchronous type)	CN1-3 CN1-14	BK+ and BK- are the braking power output and the synchronous type adopts DC192V. Wires of 0.75mm ² are recommended.
	Output brake releasing signal (only for asynchronous type)	CN1-3 CN1-14	BK+ and BK- are output brake releasing signals. Contact output of contactor is used for locking KMC normally-open contact in braking circuit. Wires of 0.75mm ² are recommended.
P0 N0	Output power	P0 (F3-2, at the lower end of air switch F3); N0 (small terminal)	The output power supplied by the ARD is DC500V; to supply controlling power for transducer. P0 is passive and N0 is negative. (<u>Connect wires according to this when YASKAWA 676GL5-JJ and Varispeed-L7B transducers are</u>

Operation Instruction of SJT-YY Elevator Automatic Rescue Device

			<u>adopted.</u>)
CP1 CP2	Output power	CN1-4 CN1-15	CP1 and CP2 are the output controlling power AC220V±10% (50HZ) provided by the ARD. Maximum power is 600W. To supply power for controlling circuit and electric circuit of door. Wires of 0.75mm ² are recommended.
IL1 IL2	Power interlock input	CN1-7 CN1-17	IL1 and IL2 supply interlock input and contact input of contactor for the ARD. They are used for the electric interlock of the ARD and elevator control system.
IL3 IL4	Power interlock output	CN1-5 CN1-16	IL3 and IL4 supply power interlock output and contact output of contactor for the control system, and is used to the electric interlock between the ARD and the control power of the control system.
IL5 IL6	Power interlock output signal	CN1-8 CN1-18	IL5 and IL6 supply interlock output and contact output of contactor for the control system, and is used to the electric interlock between the ARD and the control power of the control system.
Y4 COM4	Power failure output signal	CN1-19 CN1-9	Contact output of contactor, and is used to lock the normally-open contact of phase sequence relay in safety circuit during power failure.
Y3 COM3	Power failure output signal	CN1-20 CN1-10	Contact output of relay, and is used to supply input signal for microcomputer board.
Y2 Y6	Power failure output signal	CN1-21 CN1-13	Used to supply input signal for transducer. COM2 is a shared

Operation Instruction of SJT-YY Elevator Automatic Rescue Device

COM2		CN1-11	terminal, Y2 supplies the running signal of transducer's battery and Y6 supplies transducer failure reset signal. (used in certain transducers).
------	--	--------	--

2. Wire connecting and adjustment
 - a) Disconnect the air switches F1, F3, **F4 (this air switch should be provided, if YASKAWA 676GL5-JJ and Varispeed-L7B transducers are equipped)** and the rocker switch F2 (F1, F2, F3 and **F4** are stop switches of the ARD, and they are disconnected when they are delivered) .
 - b) Cut off the power supply to the elevator.
 - c) Connect the separate terminals of the supplied cables with the control system according to the requirements and instructions of the wiring diagram and the above table. Disconnect CN1 terminals of the cable plug-ins with the ARD temporarily. Connect side power supply of the transducer with BS+ and BS- of the ARD by the supplied wire. **If YASKAWA 676GL5-JJ and Varispeed-L7B transducers are provided, respectively connect P0 and N0 of controlling cabinet with P0 and N0 of the ARD by the supplied cables.**
 - d) Carefully check whether all the connecting wires are connected correctly. Incorrect connection may cause damage to either the ARD or the control system.
 - e) After checking the connection, plug the cable plug-in in CN1, switch on the air switches F1, F3, F4 and the rocker switch F2, and then press the power switch of UPS to supply power to the elevator.
 - f) If the elevator runs normally, then set the corresponding parameters of the transducer.
 - g) Stop the elevator at the door zone of any floor and stop the power supply, then the elevator should be automatically opened at that time.
 - h) Resume power supply to the elevator again, leave it between floors and stop power supply again, the elevator must move in the direction of light weight and opens at leveling when the emergency running conditions are met.

6. Troubleshooting and Countermeasures

1. If the power supply is abnormal after the ARD is connected, check the interlock connecting wires.
2. If nothing is displayed on transducer when power failure occurs, check whether air switches F3 and F4 are closed; check whether the output power BS+ and BS- are higher than DC192V; and check whether air switch F1 is closed as well as the connecting wires are sound and reliable.
3. Stop power supply and install the ARD. If nothing is displayed on the transducer when power is resumed, check whether air switch F1 is closed.
4. If nothing is displayed on microcomputer board when power failure occurs, check whether the rocker switch F2 is closed and the UPS power switch is closed (both should be in an “ON” status all the time).
5. If the brake of elevator is not released during emergency running, for synchronous type, check whether the braking power output is DC192V; and for asynchronous type, check whether the output brake releasing signal is normal.
6. If power failure occurs, but emergency running does not start, check whether emergency running circuit and door lock circuit are normal; whether the elevator is in non-maintenance condition; whether the normally-open contact of phase sequence locking relay is normal; and whether the input signals for microcomputer and transducer are normal.

7. Major technical parameters

1. Power supply AC220V \pm 15 % 50HZ \pm 10%
2. Output power DC192V
AC220V 50HZ I_{ed} 3A
DC110V (asynchronous type) I_{ed} 3A
3. Atmosphere temperature: 0 ~ 40
4. Relative humidity: 20 ~ 90 % without dew formed
5. Leveling accuracy: \pm 15mm
6. Applicable power for motors:

Operation Instruction of SJT-YY Elevator Automatic Rescue Device

A asynchronous type 19KW synchronous type 12KW

B asynchronous type 30KW synchronous type 22KW

7. Maximum running time: 2min

8. Cabinet dimensions:

YB: 840*240*450

YC: 574*180*721

8. Maintenance and service

1. Use the battery in clean, dry and draughty environments, and short circuit and contacting with organic solution as well as open fires are forbidden. Keep the battery upright during transportation; collision and heavy oscillation are not allowed; and the grounding of its terminals should be kept in a normal state.
2. It is recommended to check voltages of battery (F1-1 and BS- must be greater than DC192V) and conduct a trial run regularly (e.g. once a quarter).